

Omaggio a Fujimoto

di Paolo Bascetta

Disegni di Francesco Decio

**Diagrammi per uso personale/Diagrams for private use only.
Non distribuire senza permesso/Don't share without permission
Vietato qualunque uso commerciale del modello senza autorizzazione dell'autore/
Any commercial use of the model is prohibited without the author's permission.**

Esecuzione del "Twist di Fujimoto"

1

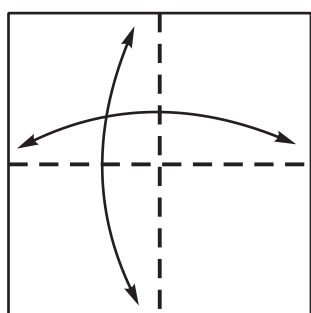

2

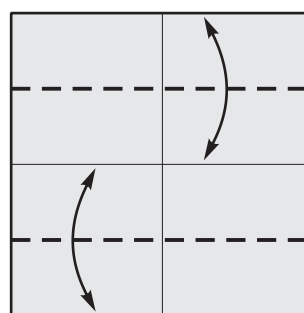

3

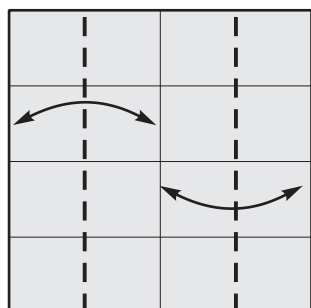

4

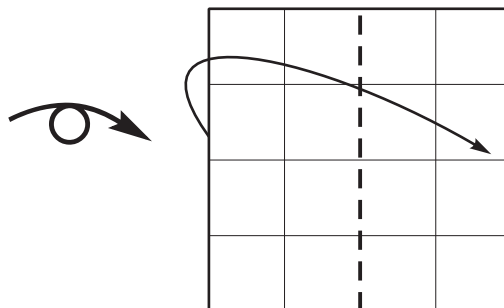

5

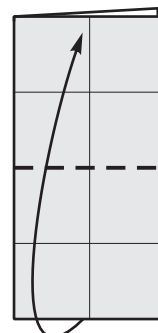

6

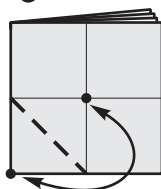

7

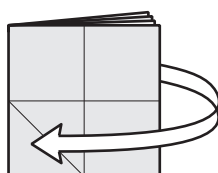

8

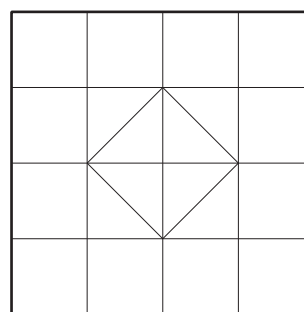



"Twist Antiorario"

1

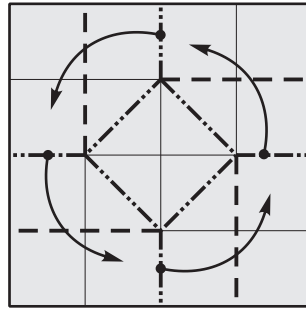

2

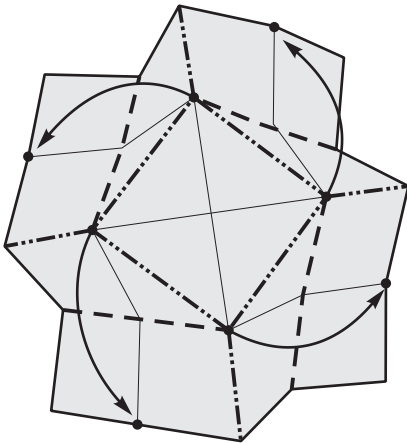

3

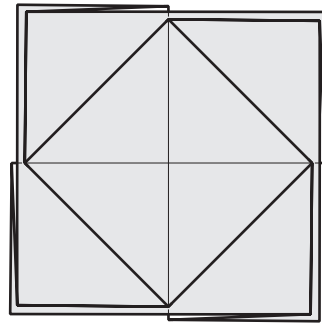

1

"Twist Orario"

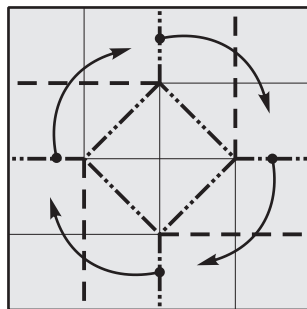

2

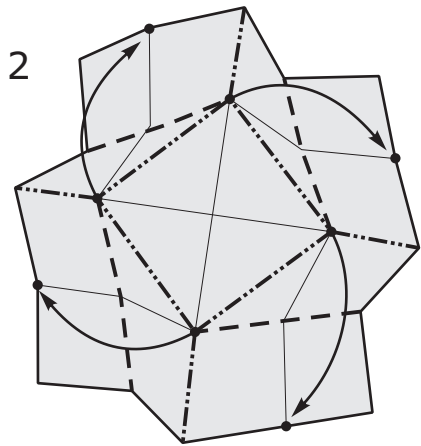

3

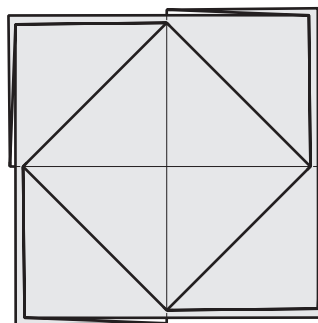

Tassellazione di "TWIST"

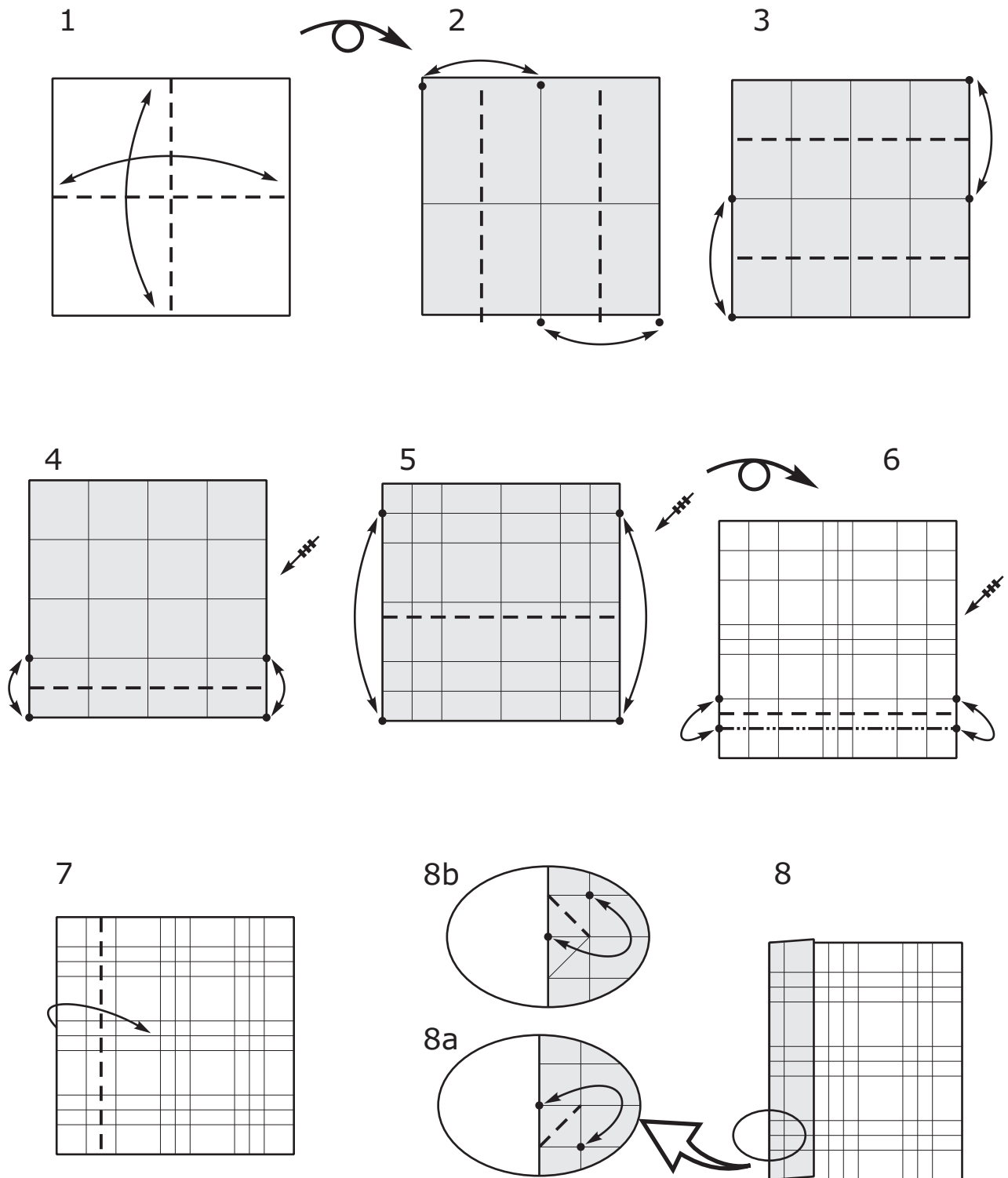

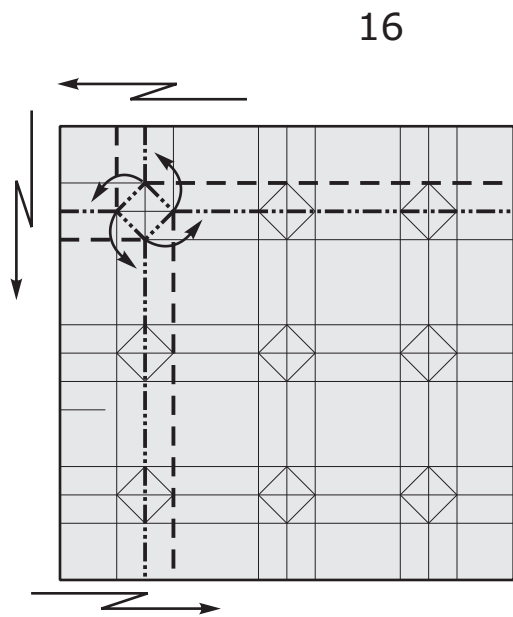
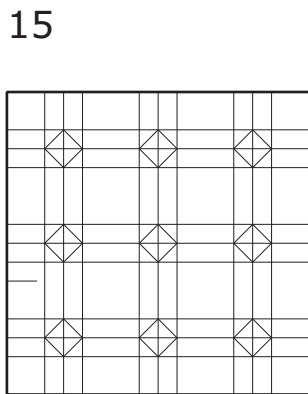
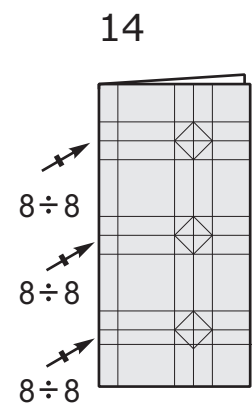
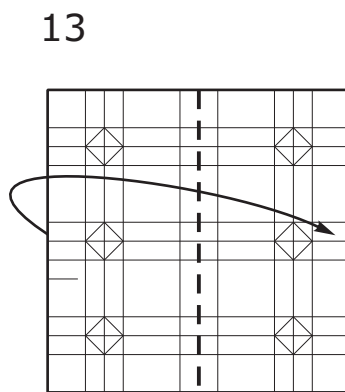
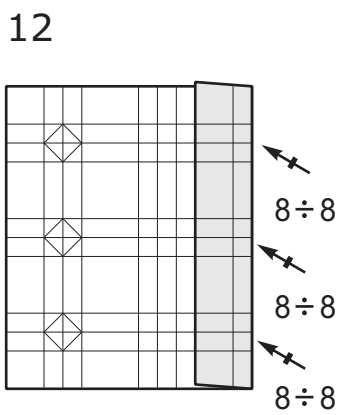
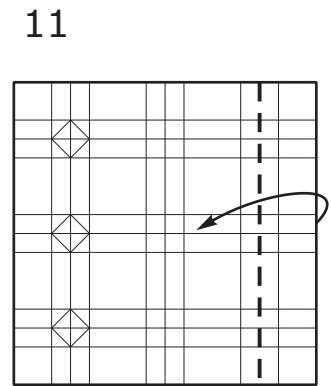
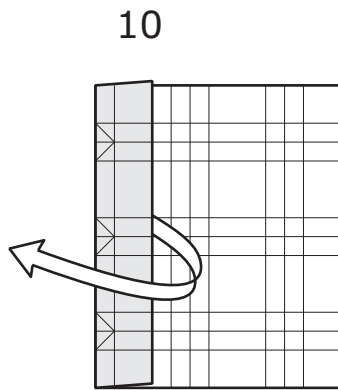
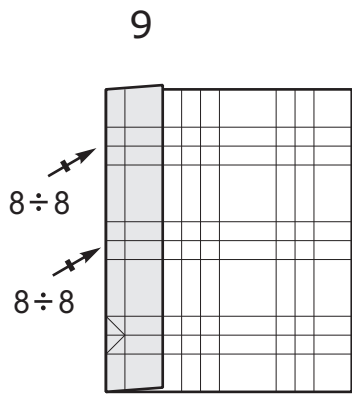

Eeguire un
"twist antiorario"
vedi pag.

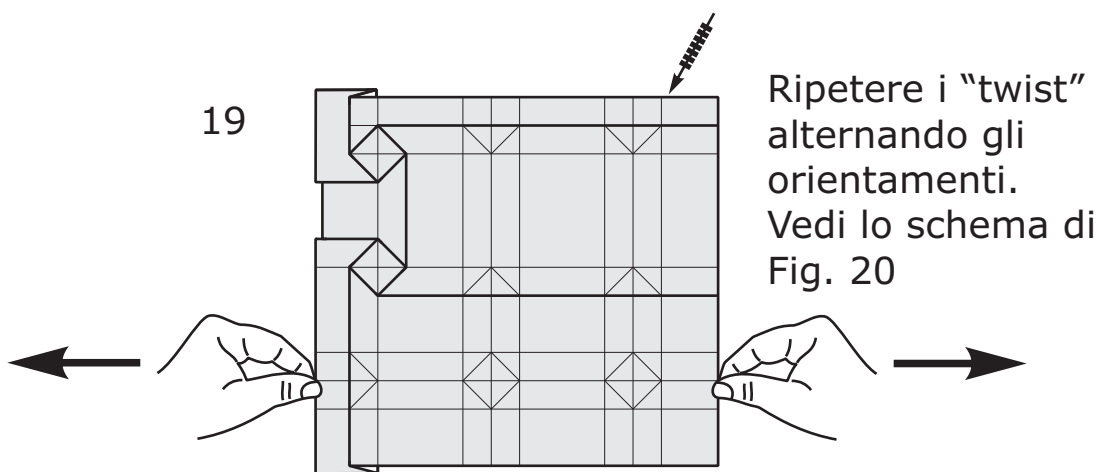
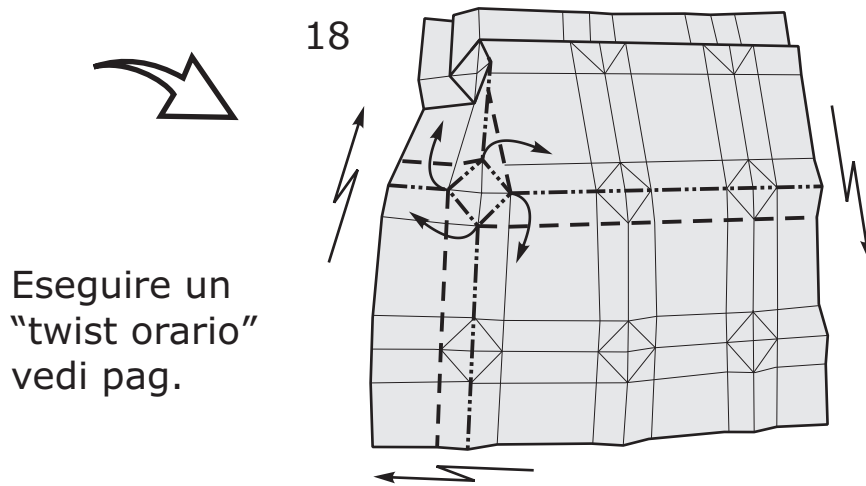
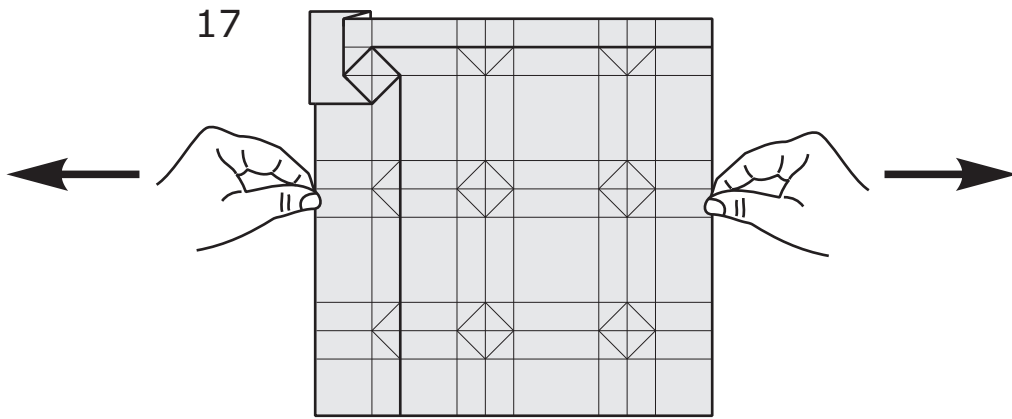

20

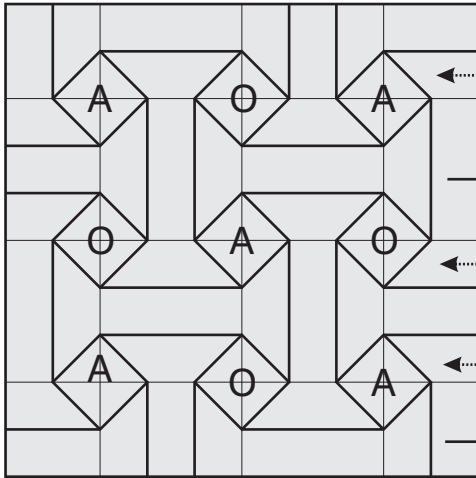

Tassello "Tipo 1" finito

21

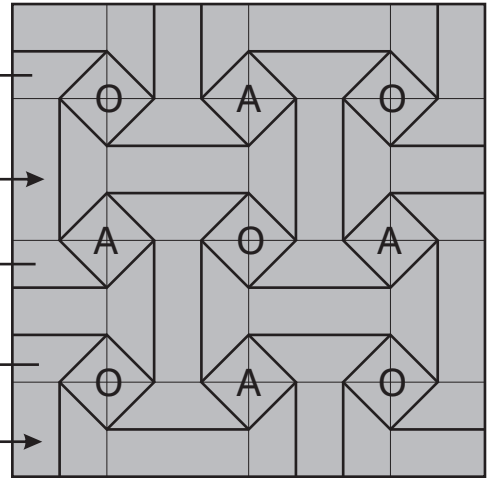

Tassello "Tipo 2" finito

Incastrare i tasselli fra loro

22

